

4QJY4.5-I

Double wide Parking Lift

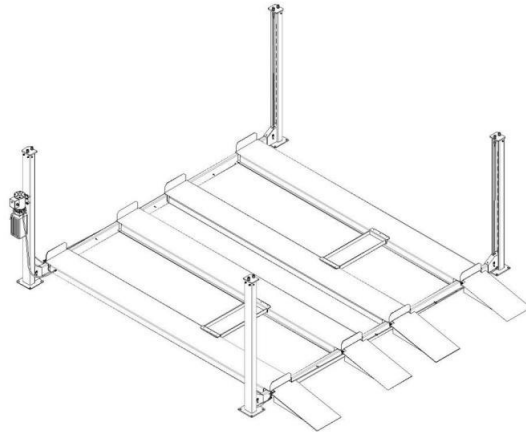

---

## Table of Contents

<b><i>Installation</i></b>	<b>3</b>
<b><i>Introduction</i></b>	<b>4</b>
<b><i>Warranty</i></b>	<b>4</b>
<b><i>Safety instructions and precautions</i></b>	<b>5</b>
<b><i>Schematic diagram</i></b>	<b>5</b>
<b><i>Technical parameters</i></b>	<b>8</b>
<b><i>Installation</i></b>	<b>9</b>
Site inspection and preparation	9
Remove hoist from the delivery vehicle	10
Unpack all loose fitting items	10
Remove runways	11
Construct and attach end frames	13
Installing the runways onto columns	15
Routing cables	17
Routing cable through the cross beam up to top of column	19
Pump assembly mounting	20
Safety latch release mechanism	21
Installation of pump assembly	22
Securing with anchor bolts	24
<b><i>Commissioning</i></b>	<b>25</b>
Sign off	25
Demonstration	25
Testing	25
<b><i>Hydraulic schematic diagram</i></b>	<b>27</b>
<b><i>Electrical schematic diagram</i></b>	<b>28</b>
<b><i>Common troubleshooting guide</i></b>	<b>29</b>
<b><i>Exploded drawing</i></b>	<b>30</b>
<b><i>Parts list</i></b>	<b>30</b>

**Final notes on 4QJY4.5-I -----READ ME FIRST-----****Be careful unpacking the lift**

Cables are packed in the lift and will drop out as the package is being unpacked, be careful removing items and keep cables clear. Even though the cables are steel rated to 5T they are easily damaged with metal parts falling or brushing against them during the unpack process.

**Hose connection to pump assembly**

We use the same pump assembly across many models. The pump supplied may have the outlet on the opposite side to that required for 4QJY4.5-I. This is resolved by swapping the hose outlet with the blank fitting on the opposite side as shown in pump assembly section.

**We require the straight fitting end of the hydraulic hose be fitted to the pump assembly as shown below. This is required to ensure the hose will clear the caster wheel rods at the base of the column. Failure to do this (caused by using the right angled end on the pump assembly) could lead to the hose getting caught on the rod causing the hose to be pulled off if the operator fails to notice this during lifting.**

**If the other hose end has a Right angled fitting, ensure that fitting guides the hose away from the pump assembly and column. Check that the hose clears the caster wheel rod during commissioning.**

**Oil grade**

The hoist will need 10 litres of ISO grade 46 oil for example Castrol Hyspin 46.

**Limit switch wiring**

A limit switch can be installed on the hoist, by routing a double insulated cable to the limit switch from the control box. We normally recommend also installing a quick blow fuse on the control box, we can supply a pre-installed cover for the control box with this fuse installed if required.

## Introduction

In this manual, contents about safety should be paid special attention. Here are some signals used in this manual.

- Read the requirement for power source and electric current on the nameplate of motor, and make sure that the power is connected by a specialized electrician.
- This hoist is rated at 4.5 T capacity of *evenly distributed weight*. any vehicle whose weight is above 4000kg is not allowed to be raised on this machine.
- Safety performance is already considered when designed and manufactured. However, appropriate training and skilled operation can also increase safety. Do not operate and repair the equipment without reading the instructions.
- Find out the requirements of power supply and current status on the motor nameplate, which must be connected by a professional and qualified electrician if not using the supplied 15Amp plug.
- In order to ensure life safety and avoid electric shock accidents, please ensure the reliable grounding of earth.
- Do not lift the load beyond the rated lifting weight of the equipment (tonnage as indicated by the name plate).

## Warranty

warrant products against faulty workmanship or defective materials for one year after date of purchase. Warranties are on a parts only basis and do not include labour.

Problems due to Improper installation, storage, lack of maintenance, lack of lubrication, incorrect operation, fair wear and tear are not covered in your warranty.

## Safety instructions and precautions

### 1.1 Text prompt sign

In the written description in this specification, the contents related to the product safety aspects need to be particularly noticed by the users. Give the prompts listed in the following table before the text paragraph.

When this sign appears before a certain paragraph of text, it means that a failure to do so according to the requirements of this paragraph will result in a serious risk of death or major injury and / or serious damage to the machinery and equipment.



When this sign appears before a paragraph, it means that if the failure to follow the requirements of this paragraph, the potential danger will gradually expand, major injury casualties and / or damage to machinery and equipment may occur.

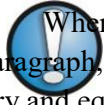

- When the written narrative following this sign, Attention and related safety requirements during the normal use, maintenance and repair of the machine are given.

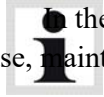

### 1.2 Purpose of equipment use

This equipment is suitable for light and small passenger cars and minivan less than 4000 Kg, and is not suitable for other special purposes.

### 1.3 Safety precautions

- 1) The operator of the parking garage must read the operation instructions carefully to effectively avoid accidents.
- 2) The operator must be familiar with the various functions and operation methods of the equipment.
- 3) Check whether the safety device is in good condition before operation, and make regular maintenance of the equipment.
- 4) When ascending and lowering operation, it is strictly prohibited to continue to use.
- 5) Overloading is strictly prohibited.

## Schematic diagram

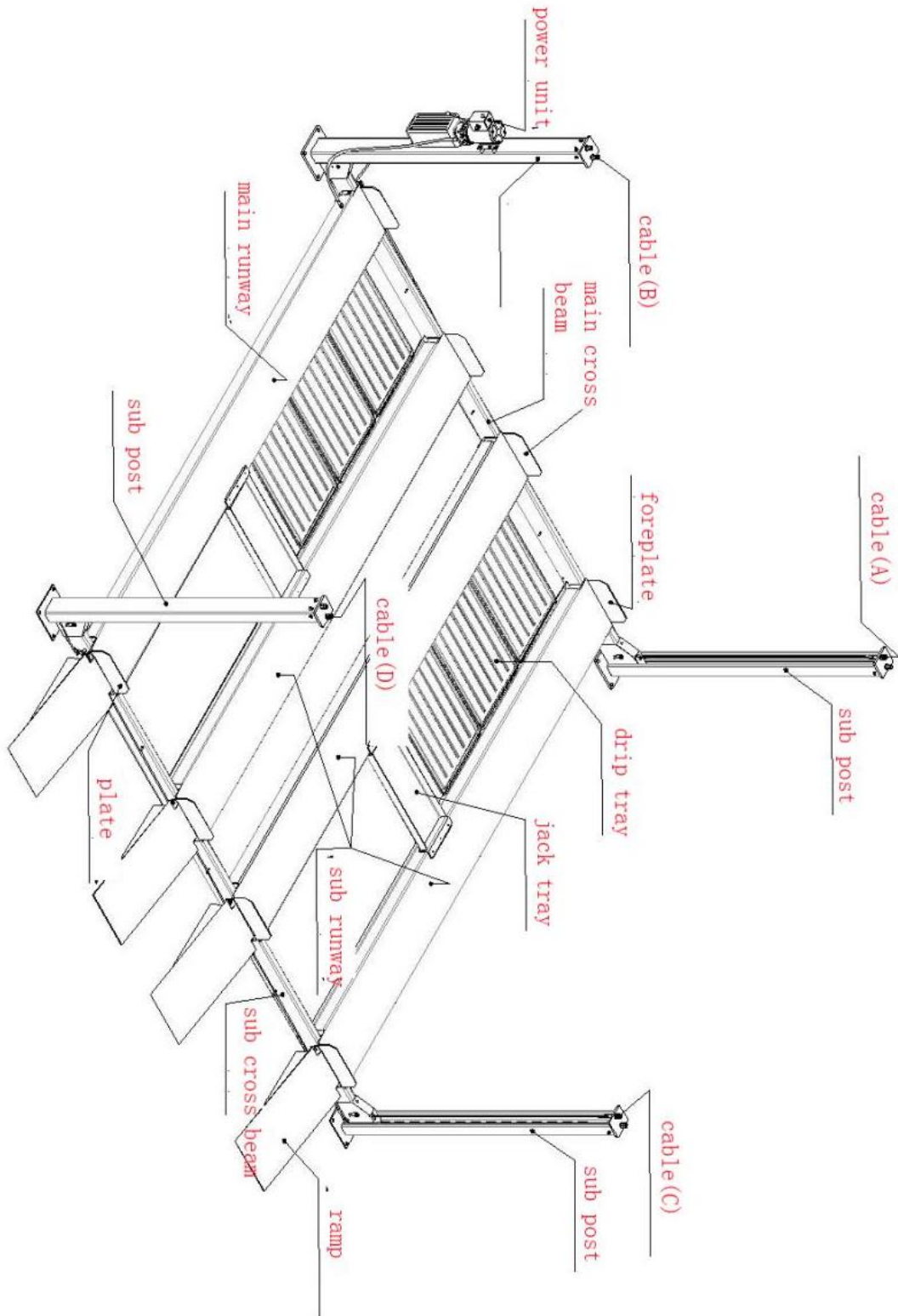

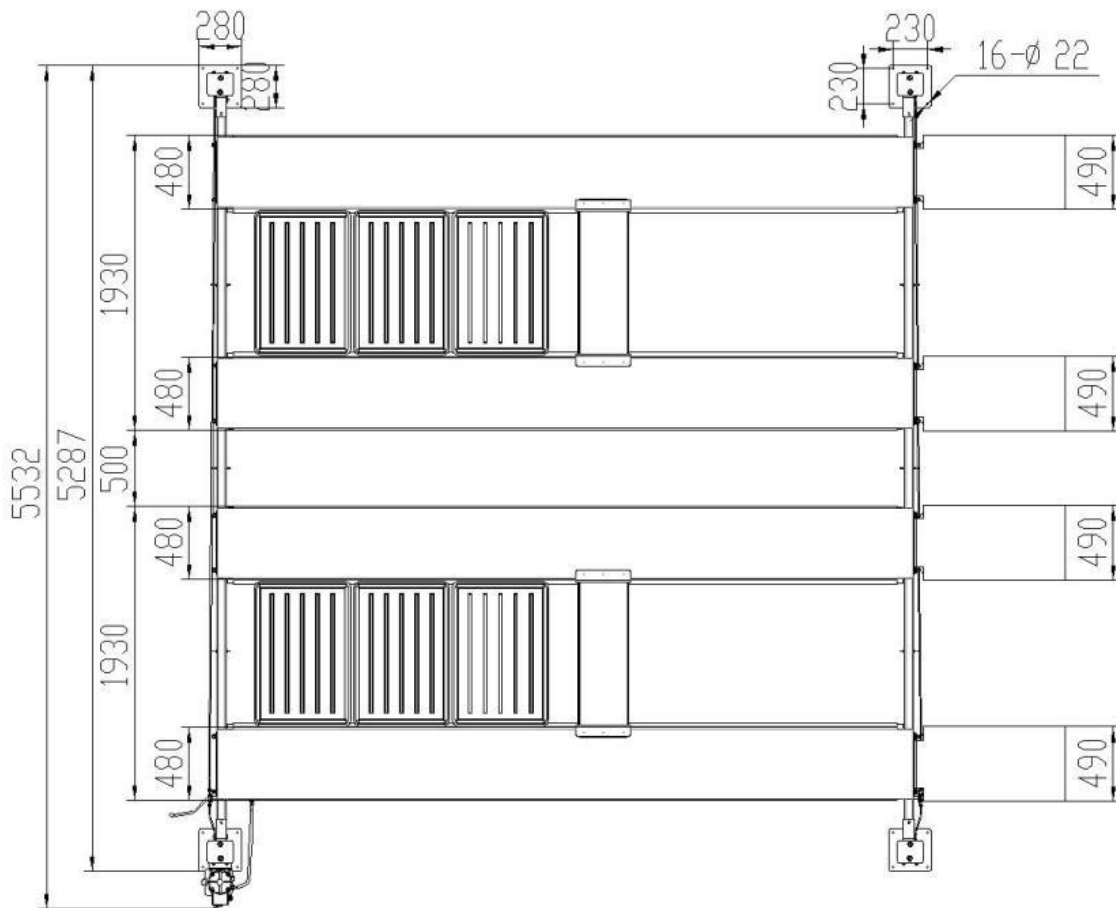
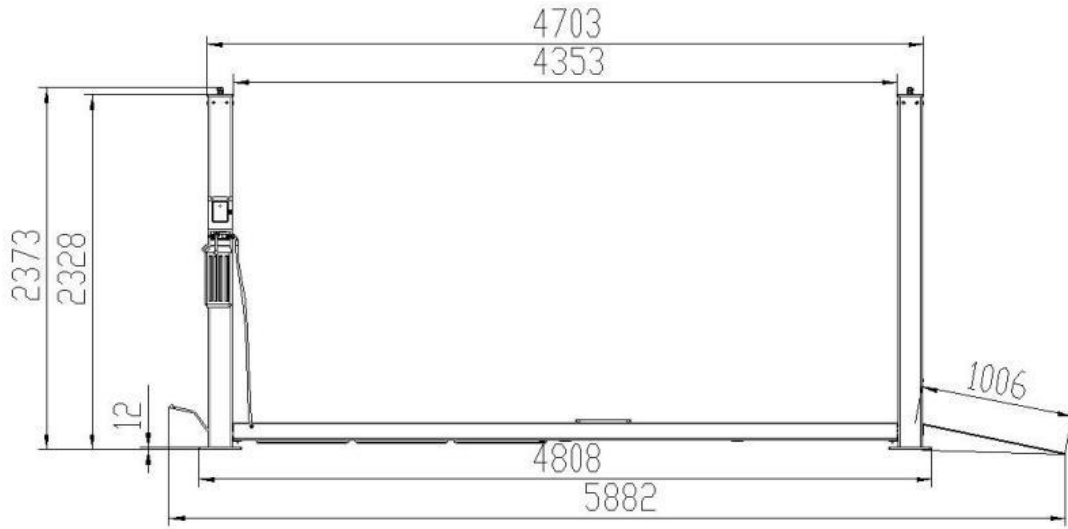

## Technical parameters

Dimensions (LxWxH)	4808x5532x2373mm
Lifting/Dropping Time	≈50s
Maximum Lifting Height	2100mm
Minimum lifting Height	120mm
Ramp length	750mm total 741mm past column
Overall length:	4886mm
Rated Load (Australian Standard)	4000kg
Motor Power	2.2kw
Working Voltage	110V/220V/380V ( 3Phase optional)
Noise Level	≤70dB(A)
Oil Pressure	20MPa
Runway width	480mm
Gap between runways	960mm
Gap between runway pairs	500mm
Ramp length down ramp	1006mm

## Installation

1. **Depth of concrete** is impacted by the underlying soil structure - if you are installing on top of shale you would require less thickness than an installation on black clay soil.

Sites should have a depth of concrete of 150mm of 25MPA concrete which on visual inspection is of solid construction. Sites that expect to have heavy vehicles being loaded constantly would have a depth of 300mm of concrete.

Options for customers concerned with floor concrete thickness:

- Install footings: Cut out a section of the floor with a concrete saw at a distance of 800mm x 800mm around the base of the hoist to a depth of 300mm. Use reinforcement rods and 25MPA quality concrete in the footings. Drill reinforcement rods into the surrounding concrete bonding with chemical fasteners. This approach is the most common form of extension as it is relatively quick to perform.

2. **Location.** vehicle hoists should be positioned so that any moving part of the hoist or the load is not less than 600 mm away from the nearest fixed structure. Where a vehicle hoist is installed adjacent to any other equipment which moves, the minimum clearance between any part of the hoist or the load and that equipment shall be 600 mm. Platform type and drive-on type vehicle hoists should be positioned so as to provide vehicles with straight entry and exit paths.

3. **Column to column leveling.** All columns must be mounted at the same floor height. This seems to be obvious **however** some sites have been up to 25mm difference in height. To measure this, use a builder's level to assess height of a level beam from column to column. Any difference in the level beam height to floor is the difference in height of the installed columns. The impact of this is that the lifting runways and arms will be at different heights which will impact the function of cross beams and safety locks

Measure the level with a builder's level across width and length directions of the installed column.

Options for customers concerned with column to column level are:

- Small variations can be managed with shims under the mounting bolts.
- In many cases the addition of a spacer plate on the lower side will address the problem.
- In some cases, the floor may require a leveling layer of concrete or steel plates to raise the low side or etch the high side to layer of concrete to achieve level.

4. **Height of enclosure.** Your shed should allow enough room for the top of the hoist to clear the roof by 100mm when installing. This will allow for the removal of the hoist after it is bolted to the floor (otherwise you will not be able to lift the column off the mounting bolts).

5. **Vehicle clearance.** Provision should be made for effective clearance above the vehicle hoist for the vehicle when the hoist is in the fully-raised position. However, where the likelihood exists of a vehicle striking an overhead obstruction when being raised, means shall be provided to prevent collision with that obstruction.

6. **Electrical.**

This hoist requires a 110 /220V /380V Volt 15amp circuit with 20amp circuit breaker.

7. **Confirm vehicle clearance.** Locate the position of the hoist intended for installation. At maximum height the runways are 2050 high, add the height of your tallest vehicle to this and compare to the ceiling to locate the appropriate installation position.

The following represents the basic steps for installation of the 4QJY4.5-I, these steps may vary depending on your installation environment. We have provided multiple descriptions of installation to ensure you are able to review the steps and learn what is required before attempting the installation.

A second more detailed description with pictures is provided in section 11 ( The first few sections are similar so don't give up, review all of the sections) . It is recommended you read both sections which will give you two descriptions of installation which should then reinforce the steps required to install and setup the hoist.

- Remove hoist from the delivery vehicle
- Unpack all loose fitting items
- Remove runways
- Construct and attach end frames
- Connect the cables
- Install the pump assembly
- Securing with anchor bolts
- Initial testing of the lift
- Connect safety release mechanism
- Final testing of the lift

## Remove hoist from the delivery vehicle

If you have arranged for the delivery via a tilt tray it is generally a good idea to have the truck to unload as close to the install location as possible. If this is not possible you may wish to construct the hoist in another area and used the dolly wheels to move the hoist into the desired location. The hoist can be moved easily when on the dolly wheels however you need to allow for the clearance of the posts to ground with is approximately 40mm. If you have collected the hoist on a trailer, you may want to unpack individual components before any movement.

## Unpack all loose fitting items

The hoist is packed with the runways and end frames forming the package frame. Carefully remove the items within the package being careful that items do not fall as you remove them. It is recommended to put some cardboard or similar material down next to the package to protect items should they fall out.

## Remove runways

At this stage the contents of the package have been removed, you now have the end frames and runways left.

The runways are removed with a lifting device or fork lift after unbolting the end frames.

Tip:

From this point on there are some installation points on the main runway ( the one with they cylinder) that you will want to perform. As the main runway is accessible during this step it is a good time to fit and check some items.) Whilst these items can be addressed at a later stage they are likely easier during this stage.

- Hydraulic line connection

Check the hydraulic line from the cylinder to the outside edge of runway. If the fittings have not been attached and you have easy access during this stage you can fit them now. If you do not want to do this now you can delay this process and connect the hose directly from the pump to the cylinder without going through the hole in the runway and fit it after you have raised the runway and located it on the safety latch.



Figure: hose fitting which may need to be fitted.

- Lubricate all pulleys wear surfaces with Wurth dry lube (**use the high pressure dry lube product**)  
Removing the pulleys is not recommended, the cables can be difficult to reroute.

- Cylinder preparation

The cylinder as supplied is in the fully raised position (ram tube inside the cylinder). When you assemble and attach the steel cable you will need to extend the ram tube to provide enough length of cable to thread into the hoist. The cylinder is most easily extended by using a ratchet strap to pull the cylinder out. Do this at a time when the cables will not cause an issue but before you lower the runways down where the cylinder will be hard to access.

- Cable preparation

When you extend the cables using a brush remove any excess debris that may have collected on the cables and recoat with Wurth dry lube or equivalent.

- Secure safety rods

Tap the safety rods on the cross beams so they do not get damaged when moving them around.

The runways once removed should be placed on wooden blocks that will enable the end frames to be



 586-742-0167

**Double wide parking Lift**

**4QJY4.5-I**

---

slotted into them. Typically use blocks of 150mm or more in height. Place both runways in a location similar to where they will be after the unit is installed. You will be able to move the unit using the dolly wheels if the unit is not in the exact position.

## Construct and attach end frames

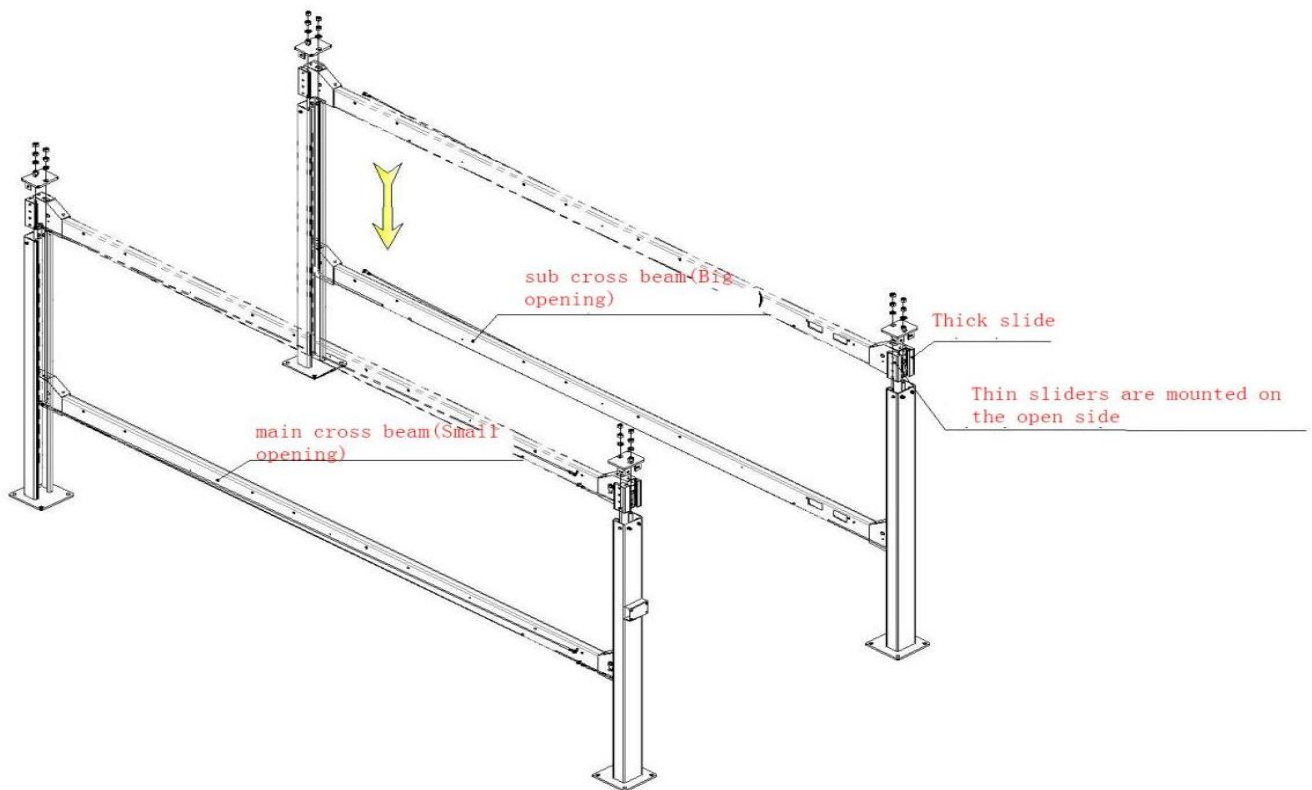

### Summary of steps

- The end frames consist of the columns and cross beam.
- Lay each column down with a support under the top of column that will enable the top end of the column to be slightly higher than the base.
- Both sides need to be at approximately the same angle and at the width required to fit the cross beam.
- **Lubricate both column internals, pulleys and nylon runners with Wurth dry lube.**
- Slide the cross beam into the columns, and lower to bottom whilst holding the safety latch in the release position.
- Install the column cap assembly.
- Move the end frames to the ends of the hoist.
- Using the bolts provided connect the cross beam to the runway. There are two larger end plates to stop the car from over running the hoist that go onto the end of the hoist furthest from the entry end and two smaller plates that are used at the entrance end as shown below.
- **Ensure that the cable will clear the bolts fixing the runway to the cross beam once the cables have tension applied. The cables will run under the the bolts directly from pulley to pulley. This will need to be checked later to double check that the bolts are installed correctly.**

The internal latch mechanism uses the contains the latches inside the cross beam as shown below.



Figure: End frame assemblies for internal locking mechanism

With the end frames installed the internal safety ladder is installed and cap assembly bolted to the top of column. When the safety ladder passes through the cross beam the latches will engage. (This photo would not be visible to an installer as it occurs inside the column)



Figure: safety ladder installed into the cross beam. Note the safety latches extending past the ladder. The cross beam may need to be raised if the latches are to be moved for cable adjustment.

## Installing the runways onto columns

1. Read the next section (routing cable) as well as this section as these two steps are performed together.
2. Confirm the hoist is in the correct location. If you have the dolly wheels package, you should use the most open area to construct the lift, then move into correct location using the dolly wheels.
3. Before installing the main runway (with cylinder), extend the cylinder out and lay cables ready for assembly. A ratchet strap is useful in this step.

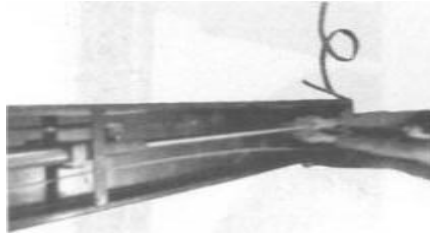

Extended rod under runway

4. Make sure the cross beams are in correct orientation
  - a. The holes for the safety release rod are on same side of cross beam as the pump assembly column
  - b. The cutouts for pulleys in cross beam are on the inside
  - c. The end plates with spacers for ramps and wheel stops are to be installed on entrance end of runway and you have the four longer bolts at that end. The end plate for other end is at the other end with the smaller bolts.
5. Position the cross beams at the same level and at a height where you can easily route the cables up from cross beam to the top of column as advised in next section.
6. Move the runways into position, being careful to route the cables through the cross beam

Make sure you lay the cables out cleanly and take care not to damage cables when moving runways, dropping a runway onto a cable will damage the cable requiring replacement.

**Important :** the diagram below you are entering from the top of the page. The pump is on bottom right, you could rotate the lift to have the pump on the top left. The pump assembly location determines how you position the runways and cross beams.

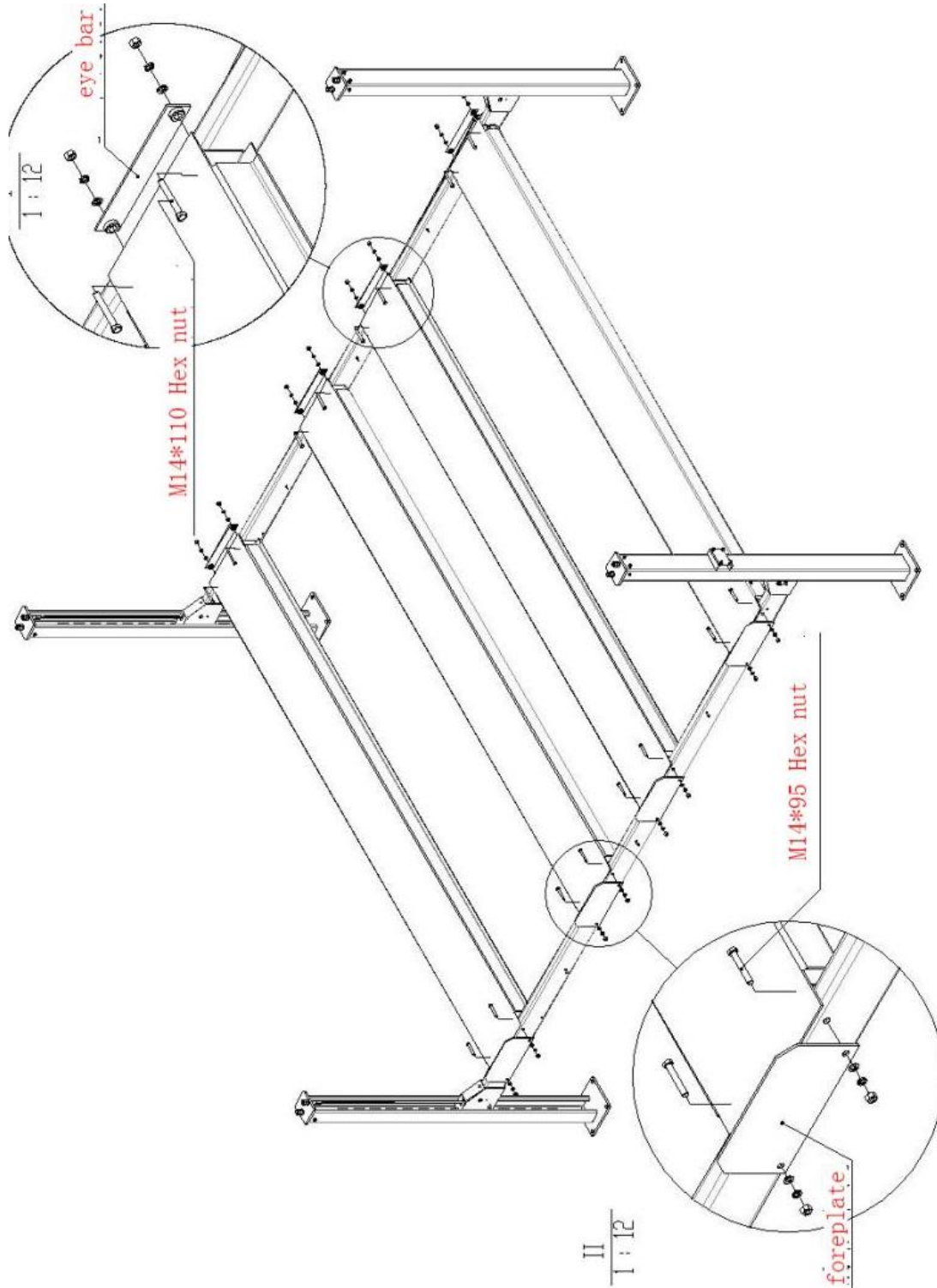

## Routing cables

The cables should have already been extended when you positioned the runways, and should now be able to be routed through the pulleys and up into the cap assembly. Install the covers over the cross beam pulleys as supplied for locks. The cable is routed through the cover, the covers are installed before attaching the cable to the top of the column.

The cable routing is shown below, note that the pulleys on the bottom of the runway feed the cable to columns along the bottom of the cross beam.

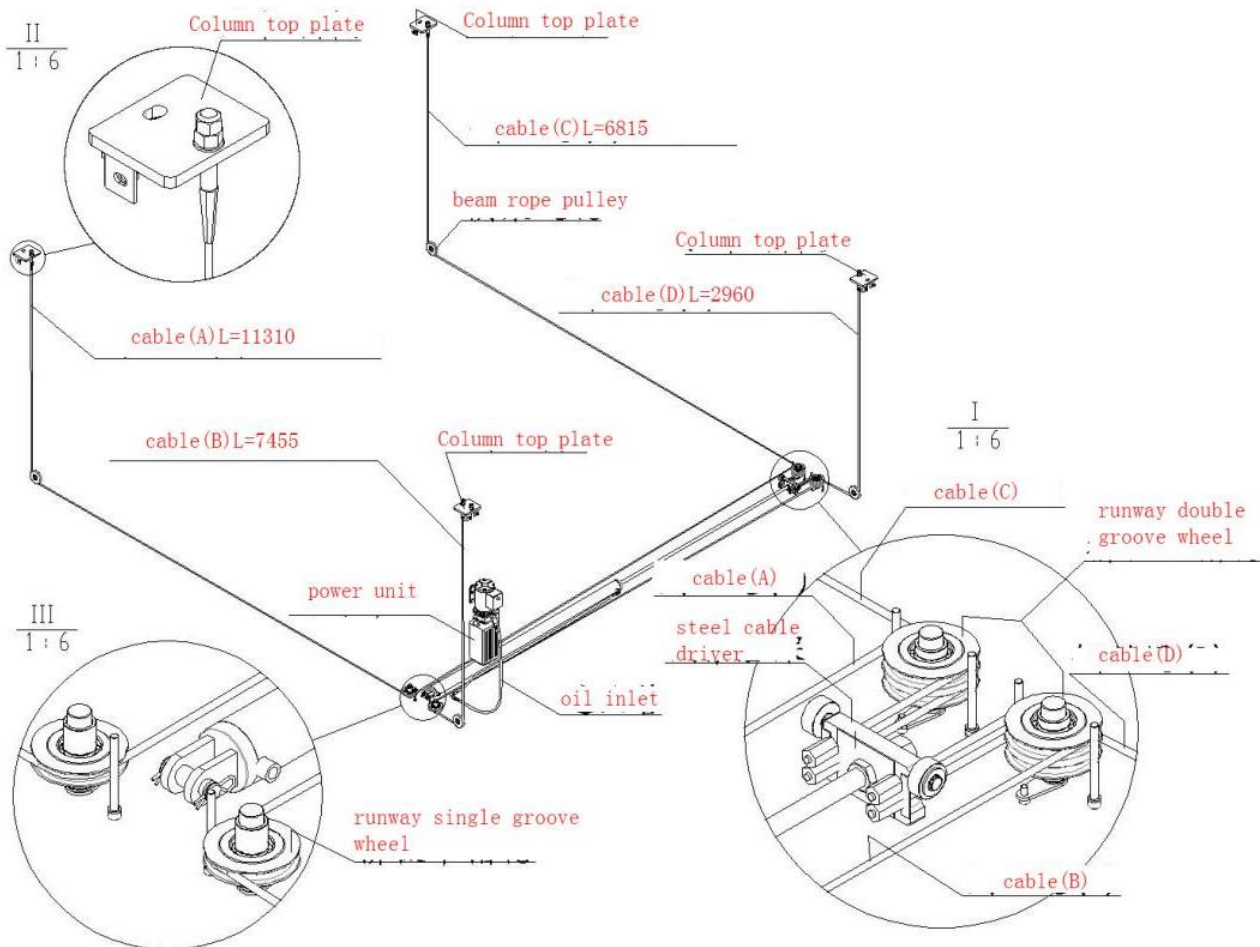

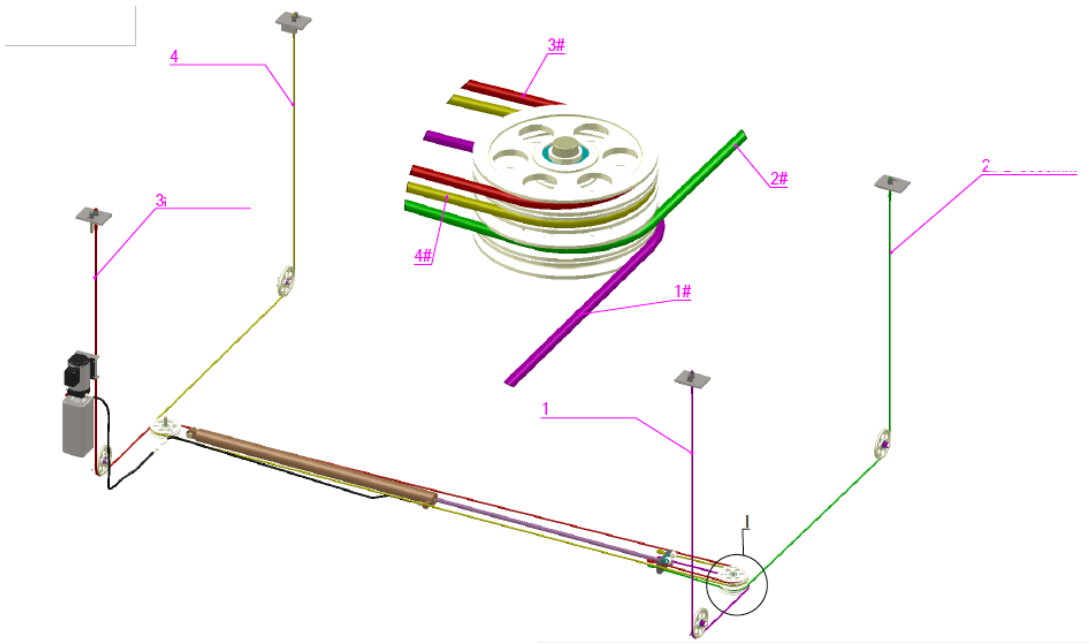

Note that cables from runway to cross beam are always the pulley on bottom of runway.

## Routing cable through the cross beam up to top of column

The cross beam may need to be supported to allow the second safety pulley to be moved inwards allowing the cable to route in its normal route (from pulley to top of column). A small wedge can be used to hold this pulley in preventing it from impacting the cable route. If a wedge is used ensure it is removed before operation of the hoist. Alternatively you can partially remove the pin that holds the larger pulley to give more slack, in this case you should not remove the pin entirely but use a smaller rod to hold the pulley in position but allowing you extra slack as you route the cable, the smaller rod can then be used to position the pulley for replacing the main pin.

**Important: Make sure the cables are routed below the bolts that locate the runway onto column.**

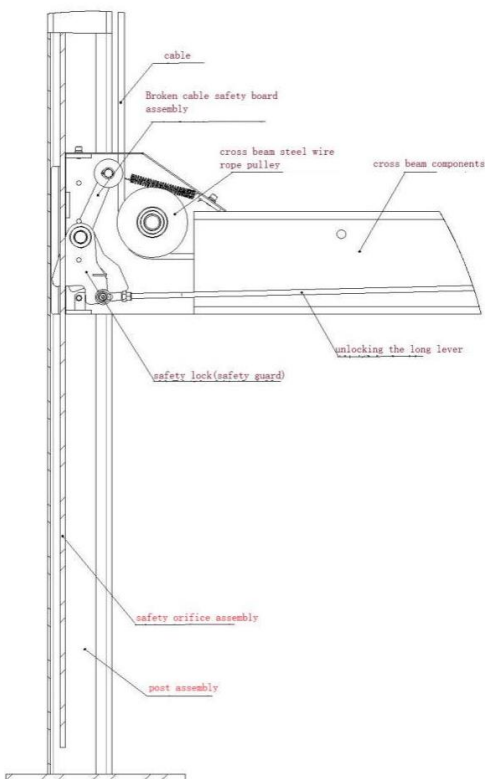

Figure: Routing of cable in internal lock mechanism



Figure: Safety ladder installed into cross beam (column would normally hide this).

1. After the cables are connected and confirmed to be in the correct location. Measure the gap between the columns to confirm the spacing is correct. .

**Important. The 4QJY4.5-I requires accurate installation of columns when mounted, failure to ensure equal separation and vertical alignment will cause columns to lock and bind in operation. The columns must all be at equal distances front to back and side to side to provide free running of the lift.**

It is recommended to wait until you have operated the hoist to confirm the columns are in the correct location and end frames run easily before installing anchor bolts.

## Pump assembly mounting

Mount the pump assembly onto the column using bolts supplied and connect the hose from pump assembly to cylinder under main runway.

The pump unit is fitted to multiple models; the outlet hose can be installed on either side of the control block by swapping the pipe joint for the plug screw on the other side. Confirm fittings are tight prior to operation.

We require the straight fitting end of the hydraulic hose be fitted to the pump assembly as shown below. This is required to ensure the hose will clear the caster wheel rods at the base of the column. Failure to do this (caused by using the right angled end on the pump assembly) could lead to the hose getting caught on the rod causing the hose to be pulled off if the operator fails to notice this during lifting. If the other hose end has a Right angled fitting, ensure that fitting guides the hose away from the pump assembly.

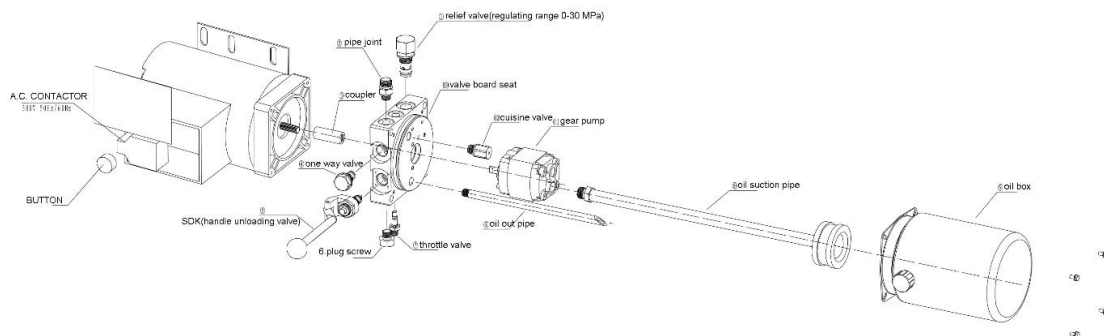

## Safety latch release mechanism

Install the rods for the safety release mechanism. The 4QJY4.5-I has extra bracing under the runway which makes this step harder than usual. You will have installed some of rods earlier in readiness for this step. Install the rods into the runway as shown connecting the T bar to the latches and threading the connecting rods inside the runway.

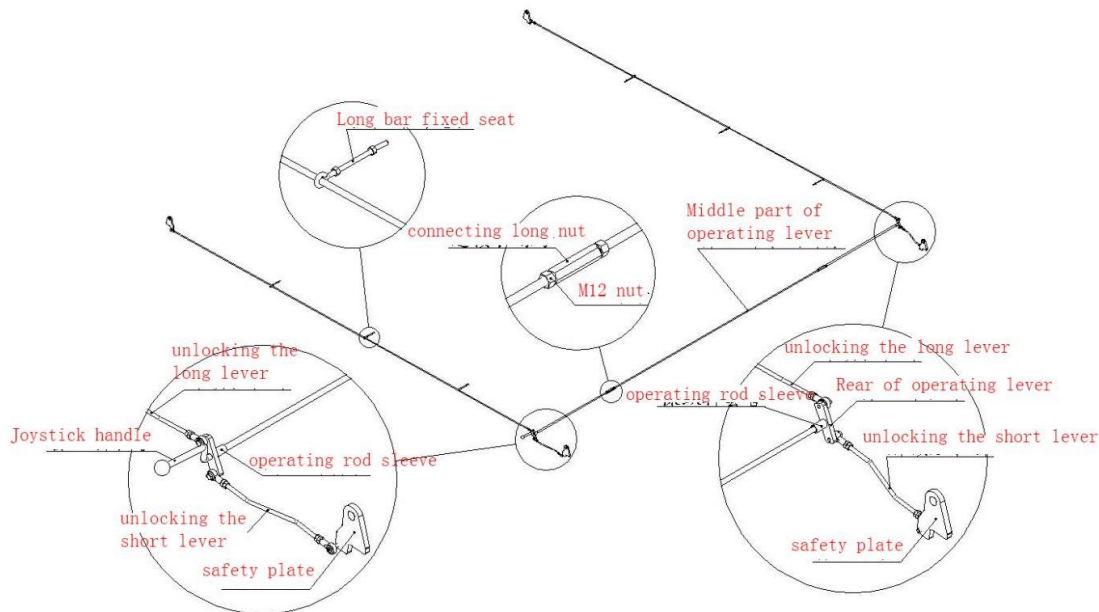

Make sure the T piece is located in the same position at both ends. i.e: both ends are at 2pm clock position and tighten the threaded connectors and lock nuts to ensure the rods remain in the same position. Check and retighten as necessary. Using an open ended hydraulic ring spanner available from tool stores as shown below and an open-ended spanner makes this task much easier



Ideal spanner for tightening lock nut on safety release rod.

**Note:** Before installing safety rod, make sure all threads are clean and take nuts and adjusters easily. When threading safety rod in you will find that you can add on the nuts and connectors most easily by installing them next the cross beam at the end of the lift.

## Installation of pump assembly

Remove the generic oil line fitting and replace with the fitting supplied with the hoist (typically this fitting is in with the anchor bolts and fittings bolts boxes.

Connect the hydraulic hose to the runway and the pump assembly fitting.



: Hydraulic hose connection to pump assembly.

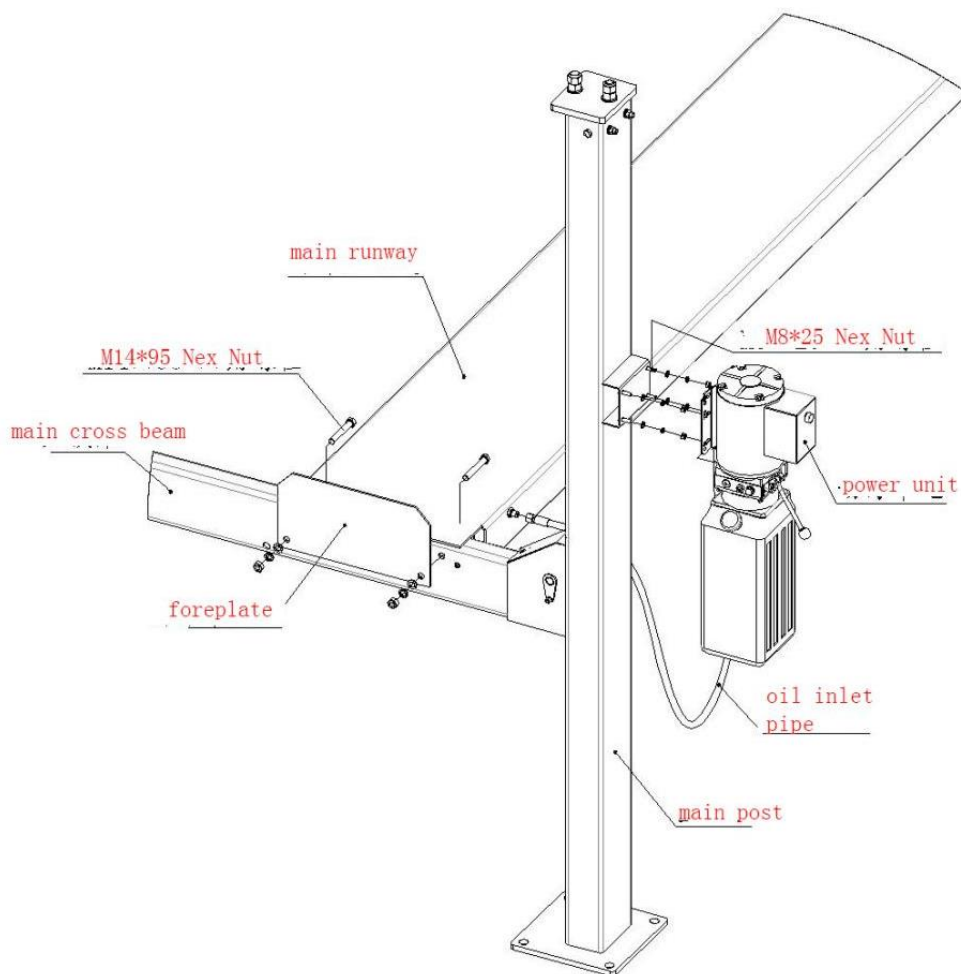

Be careful not to cross thread the fitting hydraulic connections. Ensure the connectors are fed directly onto each other and take up freely.

We require the straight fitting end of the hydraulic hose be fitted to the pump assembly as shown above. This is required to ensure the hose will clear the caster wheel rods at the base of the column. Failure to do this (caused by using the right angled end on the pump assembly) could lead to the hose getting caught on the rod causing the hose to be pulled off if the operator fails to notice this during lifting.

If the other hose end has a Right angled fitting, ensure that fitting guides the hose away from the pump assembly.

If the fitting on the runway (shown below) has not been installed yet, just connect outside of the runway and fit it later when the hoist is raised **and sitting firmly on safety latches**. If you do this be careful not to squash the line when lowering the runways.



Figure: connection of hose to pump assembly

The following step is to be performed by a licensed electrician.

- Wire the line into a 15 amp circuit. Using the supplied industrial plug. If a 3 phase pump has been used wire into the 3 phase circuit.

Using a small funnel ( auto transmission fill funnel), fill the oil tank with 10 L or ISO 46 grade hydraulic oil. Make sure you use a brand name oil and that the oil is transparent. Hydraulic oil is hygroscopic and will absorb water easily.

Note: The smallest amount of water in the closed systems will cause the cylinder to rust.

---

## Securing with anchor bolts

### Column alignment.

The columns can be fixed in the desired location. The lift can be used without anchor bolts provided the stability of the lift is checked before every operation. Once a location is selected if the lift is to be moved use drop in anchors to mount the lift, if it is permanently located in the position use tru-bolts or chemical anchors to fix the lift. Ensure all tests are passed before finalizing anchoring of the lift as once fixed in position they cannot be changed easily.

This step is included here because it logically makes sense to finally bolt the unit down to complete installation before commissioning. However it is normal to start the commissioning process and check the columns are correctly positioned and the cross beams are not binding before installing anchor bolts.

Ensure the hoist is in the correct position and that the columns are vertical +/- 1 degree in both length and width directions. The columns should be parallel to each other at each end to ensure even lifting. During this stage you can adjust the column vertical positioning with shims under the base plate. These location of the columns needs to be verified before drilling holes, the column vertical alignment can be performed during this step. The lift must be measured to be square with vertical columns. Failure to get this correct may cause the cross beams to jam as they tolerance is very tight.

Measure the outside of the anchor bolts to confirm the size, typically 4QJY4.5-I hoists are supplied with either M16 Anchor bolts that require a 16mm hole drop in anchors require a larger hole.

Anchor bolts require a tight fitment, it is suggested that you drill a test hole and confirm the bolts will be installed with a firm hit and not drop in to the hole.

Be careful to ensure the hole matches the baseplate hole, if the hole is not in the correct location the baseplate bolts will not fit unless the baseplate is modified. Holes are drilled in situ after confirmation that the columns are aligned vertically and horizontally. The hoist close tolerance will cause the lift to lock if the columns are accurately aligned.

With the anchor bolts the hole is drilled directly through the baseplate hole. The anchor bolt is tapped with the washer and nut installed and should tighten up quickly if the hole is the correct size.

The anchor bolts should all be tightened with a large ¾ inch drive socket wrench or equivalent up to 180Nm.

## Commissioning

### Sign off

AS 1418.9 require your hoist installation be signed off by a competent person. All safety devices, limit switches and control function interlocks are to be tested for correct operation. The hoist shall be loaded as near as practicable to the rated capacity for these tests.

The pressure relief valve should not require adjustment during installation.

### Demonstration

AS1418.9 section 3.7 indicates “the installer shall demonstrate the operation of the vehicle hoist to the owner”. Make sure you are advised of safe operating procedures and practices and ask questions if you are uncertain of any operation.

### Testing

Follow these steps to confirm the hoist is installed correctly and to finalize anchor bolt locations. Perform adjustments and settings with the hoist near ground level. **Do not continue to raise the hoist if problems arise as it is relatively easy to fix problems near ground level compared to raised runways.**

1. Visually, confirm that the locks are engaging and disengaging at the same time, adjusting as necessary to achieve synchronous operation. You adjust the lift with the nuts on the end of.
2. The hoist should now be able to lift with the pressing of the green button.
3. Inspect the hydraulic line to ensure not leakage at fittings.
4. Inspect the hose connecting the pump assembly to the runway, ensure that the hose has as straight fitting connection to the pump assembly and that the hose clears the rod at base of column for castor wheel kits is cleared by a distinct margin at all times. **Failure to do this may result in the hose getting caught and subsequent bursting of hose as it gets pulled apart. Check again when operating the hoist to ensure the hose connection has not changed**
5. Double check the cables are correctly installed under the cross beam locating bolts and safety release rod cable break latch pulley is on runway side of cable

The cables are meant to be installed below the bolts that connect the runway to the crossbeam clearing the bolts when tension is applied.

If the cables are not routed correctly once the cables are under tension they will pull down against the bolts slowly grinding the bolt and creating premature wear on the cables and the wear significant wear on the bolts.

If you are unsure of what you did previously, double check the cables are routed correctly, remove and inspect each bolt that holds the runway on to confirm that the cables with tension applied on are clear of the bolt. If you remove and inspect then reinstall each bolt one at a time this process will not take long to do.

**Failure to do this could in time cause the cables to wear prematurely or have the bolt wear to a point where it is worn through and would break.**

6. Lift the hoist a minimal amount and adjust the lift cables until all corners lift at the same time.

- 
7. With the runways lifting evenly the lock engagement can be adjusted. After the latch's pass the latch point (you will hear the four clicks) lower the hoist slowly and see that all latches engage, if one or more does engage that corner will continue to lower while the others are held. Inspect the adjustment and latch position on the latches to see which ones are not extending enough. If one corner is not engaging this is typically the adjustment on that corner. If one end is not engaging this is typically the T pieces on the safety are not aligned from end to end.
  8. Raise the hoist to release pressure of the locks. Adjust the corners and or the T piece sections and repeat until synchronous engagement and release of locks is achieved.
  9. Check the cable break mechanism is functional, loosen the cable and confirm the latch engages in the locking ladder.
  10. If the hoist is being fixed with anchor bolts check the columns are vertical and the cross beam nylon blocks run freely inside the column. Once this has been confirmed the columns can be fixed with the anchor bolts. Use quality masonry bits to drill the hole. If the hoist columns are not vertical and correctly laid out the cross beams may lock during operation. Take special care to measure and ensure the columns are correctly aligned.

# Hydraulic schematic diagram

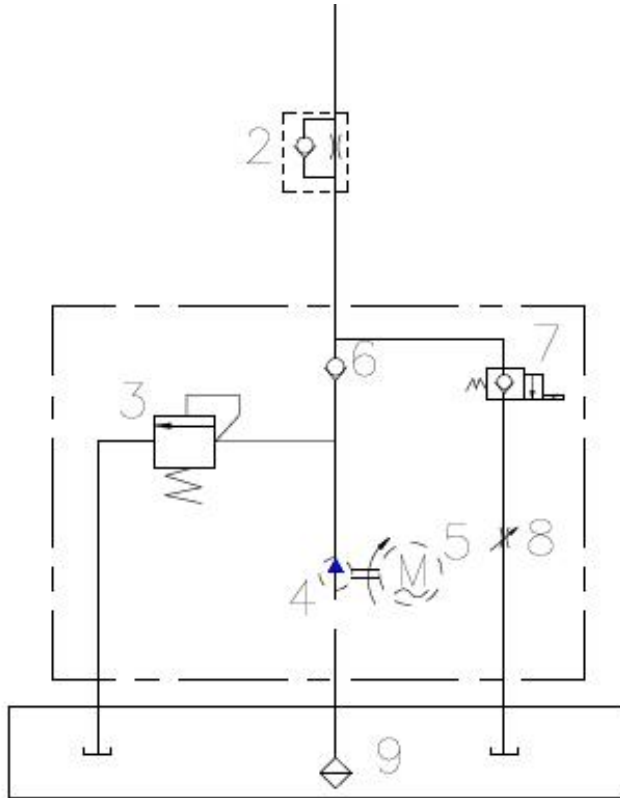

NAME	NO	NAME	NO

Hydraulic schematic diagram

# Electrical schematic diagram

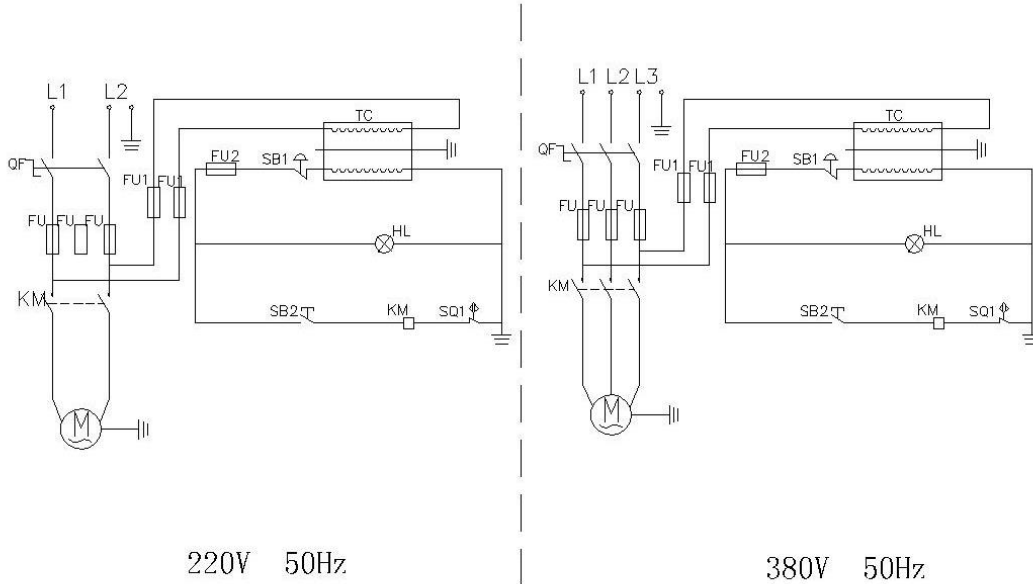

NO	CODE	NAME	MODEL	QIT	NO	CODE	NAME	MODEL	QIT
1	QF	power switch	LW26GS 20 04 2	1	7	SB1	scram button	Y090-20	1
2	FU	safety	16A 62A	3	8	HL	power indicator light	Y090-D-24V	1
3	KM	AC contactor	CJX2-1810	1	9	SB2	up botton	Y090-20	1
4	FU1	safety	10A	2	10	SQ1	limit switch	YBLX-ME 8108	1
5	FU2	safety	10A	1	11	M	motor	MQZ2-10	1
6	TC	transformer	DB-30W	1	12				

## Common troubleshooting guide

fault phenomenon	Cause the cause	Method
The motor will not start	Power supply not connected, button not functional, or electrical appliance failure	Check the power connection to motor, contactor, microswitch and rising key in the power supply fuse and motor junction box, and replace the damaged components
The motor roar does not work	a.The impeller fan lid is depressed and deformed, b.Capacitive damage, c. Voltage below level d. Overload of equipment	a. straighten impeller b.change capacitance c.Find an electrician to check supply voltage d. Reduce load
There is a crawling phenomenon in the rise	The hydraulic system contains air, the oil tank is short of oil, the load on lift is too high	Lift repeatedly to remove air and fill the tank, top up oil, if load is under safe working load you may need to adjust pressure bypass on control block
The lifting machine is noisy	The sliding part and the rotating parts are short of lubricating oil, and the pin shaft or sliders are worn	Add lubricating oil and replace the pin shaft or slider
Can't rise	① Power phase error ② Power unit failure ③ Bypass is operating, down lever or one way valve stuck open ④ Oil system oil leakage	① Adjust the power supply phase with electrician ② Repair or replace the new products ③ Inspect repair or replace valves ④ Clean up and seal leaks
The rise is slow and weak	① Insufficient hydraulic oil ② Oil leakage phenomenon in the oil circuit system ③ The filter is blocked at the pump or cylinder joint	① Supplement hydraulic oil ② Repair leaks ③ Disassemble and clean
Can't drop	① The security latch is not open ② The down level valve is blocked	① Inspect safety system and adjust ② Removed down solenoid and clean filter or replace

# Exploded drawing

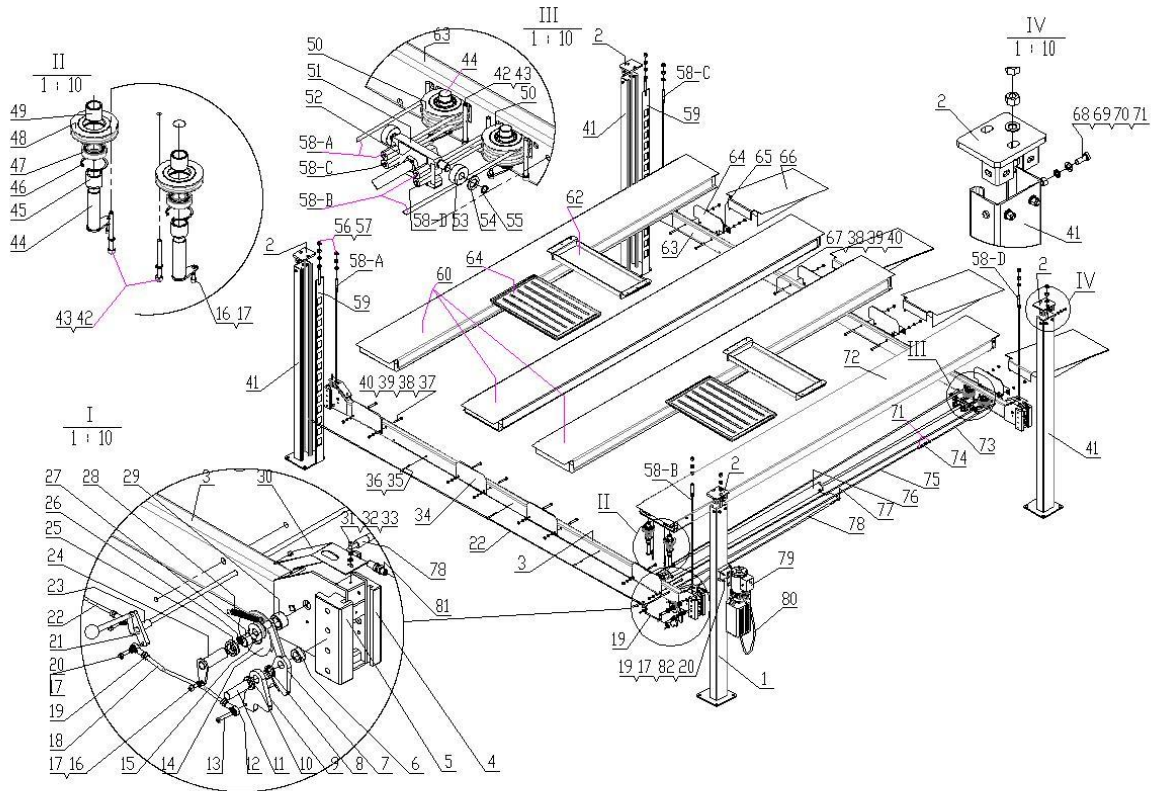

## Parts list

No	Parts name	Qty	No	Parts name	Qty
1	Main column	1	43	D10 spring washer	6

**Double wide parking Lift**
**4QJY4.5-I**

2	Top hat assembly	4	44	axle	1
3	Main crossbeam assembly	1	45	Lower bush	4
4	Nylon block(2)	4	46	D62 snap ring	4
5	Nylon block(1)	4	47	bearing	6
6	Fixing bush	4	48	Single pulley	2
7	Left, right cable breaking	Each	49	Single pulley upper bush	2
8	Left, right spring	Each	50	Double pulley	2
9	Safety latch	4	51	Cylinder mount assembly	1
10	Fixing bush L=6	4	52	Lock parts for cylinder mount	1
11	Axle L=71	4	53	Nylon pulley	2
12	M8 bearing	8	54	D18 flat washer	2
13	M8*12.5 bolt	4	55	D18 snap ring	2
14	crossbeam pulley	4	56	D20 flat fasher	8
15	Pulley for cable breaking	4	57	M20 nut	20
16	M8*12 bolt	8	58	Steel cable A=11310mm, B=7455mm C=6815mm, D=2960mm	1
17	D8 spring washer	16	59	Locking ladder	4
18	Short rod L=270	2	60	Sub runway	3
19	M8 nut	12	61	Drip tray	6
20	M8*25 nut	8	62	Jack tray	2
21	Linkage rod assembly	1	63	Sub crossbeam	1
22	Long rod L=4590	2	64	Rear stopper	4
23	Positioning bush L=30	2	65	bracket	4
24	Pulley axle assembly	4	66	Approach ramp	2
25	Bush L=11	4	67	M14*110 bolt	8
26	D16 snap ring	4	68	M12*30 bolt	16
27	Oilless bearing	4	69	D12 flat washer	16
28	Cable breaking latch spring	4	70	D12 spring washer	16
29	Long bush	4	71	M12 nut	20
30	Crossbeam cover	Each	72	Main runway	1
31	M6*12 bolt	8	73	Short linkage rod	1
32	D6 spring washer	8	74	nut	2
33	Flat washer	8	75	Middle rod L=2660mm	1
34	stopper	4	76	cylinder	1
35	Rod bolt	6	77	Throttle valve	1
36	M6 nut	12	78	Hydraulic hose L=2040mm	1
37	M14*95 bolt	8	79	Power unit	1
38	D14 flat washer	16	80	Hydraulic hose L=2200mm	1
39	D14 spring washer	16	81	L fitting	1
40	M14 nut	16	82	D8 flat washer	4
41	Sub column assembly	3	83		
42	M10*110 bolt	6	84		